

T-Einschraubverschraubungen DIN 158

Metrisches Gewinde (kegelig)
 Form C, DIN 3852 Teil 2 bzw.
 Metrisches Gewinde (zylindr.)
 Dichtkante Form B,
 DIN 3852 Teil 2

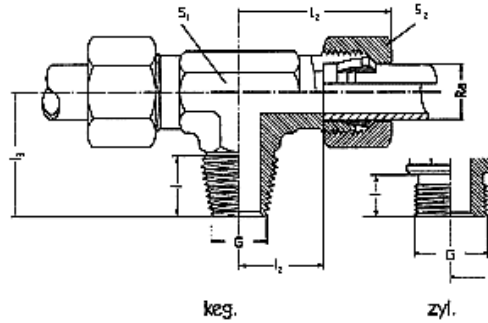

Reihe	PN	Ra	NPT	i	S2	S1	L2	I2	I3	Gewicht %	Artikel	
LL	100	4	M 8x1 keg.	8	10	9	21	11,0	17	2,8	TEV-04LLMK 08x1,0	
		6	M 10x1 keg.	8	12	9	21	9,5	17	3,4	TEV-06LLMK 10x1,0	
		8	M 10x1 keg.	8	14	12	23	11,5	20	4,7	TEV-08LLMK 10x1,0	
L	250	6	M 10x1 keg.	8	14	12	27	12,0	20	6,0	TEV-06LMK 10x1,0	
		8	M 12x1,5 keg.	12	17	12	29	14,0	26	9,2	TEV-08LMK 12x1,5	
		10	M 14x1,5 keg.	12	19	14	30	15,0	27	11,7	TEV-10LMK 14x1,5	
		12	M 16x1,5 keg.	12	22	17	32	17,0	28	16,0	TEV-12LMK 16x1,5	
		15	M 18x1,5 keg.	12	27	19	36	21,0	32	19,3	TEV-15LMK 18x1,5	
		160	18	M 22x1,5 keg.	14	32	24	40	23,5	36	29,2	TEV-18LMK 22x1,5
			22	M 26x1,5	16	36	27	44	27,5	42	36,9	TEV-22LMK 26x1,5
	100	28	M 33x2	18	41	36	47	30,5	48	55,0	TEV-28LMK 33x2,0	
		35	M 42x2	20	50	41	56	34,5	54	84,9	TEV-35LMK 42x2,0	
		42	M 48x2	22	60	50	63	40,0	61	142,2	TEV-42LMK 48x2,0	
		S	630	6	M 12x1,5 keg.	12	17	12	31	16,0	26	10,9
8	M 14x1,5 keg.	12		19	14	32	17,0	27	14,0	TEV-08SMK 14x1,5		
10	M 16x1,5 keg.	12		22	17	34	17,5	28	19,0	TEV-10SMK 16x1,5		
12	M 18x1,5 keg.	12		24	17	38	21,5	28	24,5	TEV-12SMK 18x1,5		
14	M 20x1,5 keg.	14		27	19	40	22,0	32	26,4	TEV-14SMK 20x1,5		
400	16	M 22x1,5 keg.		16	30	24	43	24,5	32	28,4	TEV-16SMK 22x1,5	
	20	M 27x2		16	36	27	48	26,5	42	45,5	TEV-20SMK 27x2,0	
	25	M 33x2	18	46	36	54	30,0	48	87,5	TEV-25SMK 33x2,0		
	250	30	M 42x2	20	50	41	62	35,5	54	121,5	TEV-30SMK 42x2,0	
		38	M 48x2	22	60	50	72	41,0	61	174,0	TEV-38SMK 48x2,0	

